



ETA-Danmark A/S
Göteborg Plads 1
DK-2150 Nordhavn
Tel. +45 72 24 59 00
Fax +45 72 24 59 04
Internet www.etadanmark.dk

Authorised and notified according
to Article 29 of the Regulation (EU)
No 305/2011 of the European
Parliament and of the Council of 9
March 2011

MEMBER OF EOTA



European Technical Assessment ETA-09/0273 of 28/04/2015

I General Part

Technical Assessment Body issuing the ETA and designated according to Article 29 of the Regulation (EU) No 305/2011: ETA-Danmark A/S

Trade name of the construction product:

Paslode Connector nails,
Paslode Connector screws

Product family to which the above construction product belongs:

Nails and screws for use in nailing plates in timber structures

Manufacturer:

ITW Construction Products
Gl. Banegaardsvej 25
DK-5500 Middelfart
Denmark
Tel. +45 63 41 10 10
Fax +45 63 41 10 11
Internet www.nkt-fasteners.dk

Manufacturing plant:

ITW Construction Products
Gl. Banegaardsvej 25
DK-5500 Middelfart
Denmark

This European Technical Assessment contains:

10 pages including 2 annexes which form an integral part of the document

This European Technical Assessment is issued in accordance with Regulation (EU) No 305/2011, on the basis of:

EAD 130033-00-0603 - Nails and screws for use in nailing plates in timber structures, edition 2015-03

This version replaces:

The previous ETA with the same number issued on 2011-06-27 and expiry on 2015-04-28

Translations of this European Technical Assessment in other languages shall fully correspond to the original issued document and should be identified as such.

Communication of this European Technical Assessment, including transmission by electronic means, shall be in full (excepted the confidential Annex(es) referred to above). However, partial reproduction may be made, with the written consent of the issuing Technical Assessment Body. Any partial reproduction has to be identified as such.

II SPECIFIC PART OF THE EUROPEAN TECHNICAL ASSESSMENT

1 Technical description of product and intended use

Technical description of the product

Paslode Connector Nails are made from cold formed steel thread or stainless steel. The shank is cylindrical and made with ribs or square twisted on part of the shank. See annex A, drawing 1.

Paslode Connector screws are made from tempered or stainless steel. The shank is cylindrical and threaded on the majority of the shank. See annex A, drawing 2.

Range

The range covers nails with 2 different diameters; 4,0 mm and 3,4 mm.

For nails with a diameter of 4 mm the length varies from 35 mm to 60 mm. These nails are all ring shank nails.

For nails with a diameter of 3,4 mm the length is 35 mm. They are either square twisted or ring shank nails.

Other dimensions appear from Annex A.

The range covers screws with a diameter of 5 mm, the length varies from 25 to 50 mm. Other dimensions appear from Annex A.

2 Specification of the intended use in accordance with the applicable EAD

The nails are and screws used for steel and aluminium nailing plates and three-dimensional steel and aluminium nailing plates for connections in load bearing timber structures with members of solid timber, glued laminated timber and similar glued members or wood-based structural members, where requirements for mechanical resistance and stability and safety in use in the sense of the Basic Works Requirements 1 and 4 of Regulation (EU) 305/2011 shall be fulfilled.

Note: The requirement to the material of the wood members can be fulfilled by using the following materials:

- *Solid timber classified to C14-C40 according to EN 338 / EN 14081*
- *Glued members of timber classified to C14 – C40 according to EN 338 / EN 14081.*
- *Glued laminated timber classified to GL24c or better according to EN 1194/EN 14080.*
- *Solid Wood Panels, SWP according to EN 13353.*

- *Laminated Veneer Lumber LVL according to EN 14374*
- *Plywood according to EN 636*
- *Oriented Strand Board, OSB according to EN 300*

The design of the timber connections shall be based on the characteristic load-carrying capacities of the nails and screws. The design capacities shall be derived from the characteristic capacities in accordance with Eurocode 5 or a similar national Timber Code.

The tables below states the service classes according to Eurocode 5 where the nails and screws are to be used.

Nail type	For service classes
Hardened	1, 2
GALV-PLUS®	1, 2
HDG	1, 2, 3
A2 (AISI 304)	1, 2, 3
A4 (AISI 316)	1, 2, 3
UK Twist, Hardened	1, 2
UK Twist	1, 2
UK Ring, Hardened	1, 2
UK Ring	1, 2

The nail designations GALV-PLUS® and HDG indicate two different types of corrosion protection.

Screw type	For service classes
Connector screw (normal)	1, 2
Connector screw, stainless, A4 (AISI 316)	1, 2, 3

The scope of the nails and screws regarding resistance to corrosion shall be defined according to national provisions that apply at the installation site considering environmental conditions.

The provisions made in this European Technical Assessment are based on an assumed intended working life of the Paslode Nails and Paslode Screws of 50 years.

The indications given on the working life cannot be interpreted as a guarantee given by the producer or Assessment Body, but are to be regarded only as a means for choosing the right products in relation to the expected economically reasonable working life of the works.

3 Performance of the product and references to the methods used for its assessment

Characteristic	Assessment of characteristic
3.1 Mechanical resistance and stability*) (BWR1)	
Withdrawal and lateral load-carrying capacity	See Annex B
Tensile capacity	See Annex B
Torsional strength of screws	See Annex B
3.2 Safety in case of fire (BWR2)	
Reaction to fire	The nails and screws are made from steel classified as Euroclass A1 in accordance with EN 1350-1 and EC decision 96/603/EC, amended by EC Decision 2000/605/EC
3.3 Hygiene, health and the environment (BWR3)	
Influence on air quality	The product does not contain/release dangerous substances specified in TR 034, dated March 2012 **)
3.8 General aspects related to the performance of the product	
	The nails and screws have been assessed as having satisfactory durability and serviceability when used in timber structures using the timber species described in Eurocode 5 and subject to the conditions defined by service class 1, 2 and 3
Identification	See Annex A

*) See additional information in section 3.8 – 3.9.

**) In addition to the specific clauses relating to dangerous substances contained in this European Technical Assessment, there may be other requirements applicable to the products falling within its scope (e.g. transposed European legislation and national laws, regulations and administrative provisions). In order to meet the provisions of the Construction Products Regulation, these requirements need also to be complied with, when and where they apply.

3.9 Mechanical resistance and stability

The load-carrying capacities for Paslode Connector Nails and Screws are applicable to the wooden materials mentioned in clause 1 for intended use. The term timber has been used in the following meaning all materials mentioned under intended use.

The formulas for the load-carrying capacities are restricted to characteristic densities of the wooden materials up to 480 kg/m³. Even though the wood based material may have a larger density, this must not be used in the formulas.

The capacities stated below are applicable to connections with metal plates.

3.9.1 Paslode Connector nails

Axial withdrawal capacity

The characteristic axial withdrawal capacity, $F_{ax,Rk}$, of a Paslode Connector Nail in a metal plate shall be calculated from:

$$F_{ax,k} = d_{nom} l_{ef} f_{ax,k}$$

where

l_{ef} is the effective length of the nail ($l_g - l_p$)
 d_{nom} is the nominal diameter of the nail

4 mm nails

- For the nail types
- GALV-PLUS®
- HDG
- A2
- A4
- Hardened

with $d_{nom} = 4$ mm the withdrawal strength is

$$f_{ax,k} = 10,7 (\rho_k/350) \text{ MPa}$$

for nominal nail lengths 40, 50 and 60 mm.

For nominal nail length 35 mm the strength shall be reduced by 6 %.

For nail type Hardened with nominal length 35 mm, the strength shall be reduced by 25 %.

UK nails

For nail types UK twist and UK twist, Hardened with $d_{nom} = 3,4$ mm and $l_{nom} = 35$ mm

$$F_{ax,k} = 6,3 (\rho_k/350) \text{ MPa}$$

For nail type UK ring and UK ring, Hardened with $d_{nom} = 3,4$ mm and $l_{nom} = 35$ mm

$$F_{ax,k} = 9,5 (\rho_k/350) \text{ MPa}$$

For nail type UK Ring Hardened the strength shall be reduced by 25 %.

Lateral capacity

The characteristic lateral load-carrying capacity, $F_{v,Rk}$, of a Paslode Connector Nail in a metal plate shall be calculated from:

4 mm nails

$$F_{v,k} = 2,04(\rho_k/350)(l/40 \text{ mm})^{0,8} e_{type} e_t e_{grain} e_{hard35} \text{ kN}$$

with

$$e_{type} = \begin{array}{l} 1,00 \text{ for GALV-PLUS®}, \\ 0,93 \text{ for HDG}, \\ 0,96 \text{ for A2} \\ 1,06 \text{ for A4} \\ 1,00 \text{ for Hardened} \end{array}$$

$$e_t = \begin{array}{l} 1,00 \text{ for 2 mm and 0,92 for 0,9 mm plate} \\ \text{thickness} \end{array}$$

$$e_{grain} = \begin{array}{l} 1,00 \text{ for load parallel and 1,12 for load} \\ \text{perpendicular to grain} \end{array}$$

$$e_{hard35} = \begin{array}{l} 0,87 \text{ for nail type Hardened with length 35} \\ \text{mm, otherwise 1,00} \end{array}$$

and where

$$\begin{array}{ll} l & \text{is in nominal nail length in mm} \\ \rho_k & \text{is the characteristic density in kg/m}^3 \end{array}$$

For plate thicknesses between 0,9 mm and 2 mm linear interpolation can be used.

For plate thicknesses between 2 mm and 4 mm the value for 2 mm can be used.

UK nails

$$F_{v,k} = 1,30(\rho_k/350)e_{type} e_{grain} e_t \text{ kN}$$

with

$$e_{type} = \begin{array}{l} 1,00 \text{ for UK ring, Hardened} \\ 0,9 \text{ for UK ring} \\ 0,80 \text{ for UK twist, Hardened} \\ 0,72 \text{ for UK twist} \end{array}$$

$e_{grain} = 1,00$ for load parallel and 1,30 for load perpendicular to grain.

$e_t = 1,00$ for 2 mm and 0,90 for 0,9 mm plate thickness

and where

ρ_k is the characteristic density in kg/m³.

The expression is valid for plate thicknesses from 0,9 mm to 4 mm.

Tensile capacity

The characteristic tensile capacity $F_{tens,k}$, of a Paslode Connector Nail is stated in Tables B2 and B4 in Annex B depending on the nail type.

Yield moment

The characteristic yield moment $M_{y,k}$, of a Paslode Connector Nail is stated in Table B2 and B4 in Annex B depending on the nail type.

3.9.2 Paslode Connector screws

Axial withdrawal capacity

The characteristic axial withdrawal capacity, $F_{ax,Rk}$, of a Paslode Connector Screw in a metal plate shall be calculated from:

$$F_{ax,k} = d_{nom} l_{ef} f_{ax,k}$$

where

l_{ef} is the effective length of the screw ($l_g - d_{nom}$)
 d_{nom} is the nominal diameter of the screw (= 5 mm)
 $f_{ax,k} = 15,2 (\rho_k/350)$ MPa

for nominal screw lengths 25, 35, 40 and 50 mm.

Lateral capacity

The characteristic lateral load-carrying capacity, $F_{v,Rk}$, of a Paslode Connector Screw in a metal plate shall be calculated from:

$$F_{v,k} = 2,36(\rho_k / 350)(l/40 \text{ mm}) e_t e_{grain} \text{ kN}$$

with

$e_t = 1,00$ for 2 mm and 0,9 for 0,9 mm plate thickness

$e_{grain} = 1,00$ for load parallel and 1,08 for load perpendicular to grain

and where

l is in nominal screw length in mm

ρ_k is the characteristic density in kg/m³

For plate thicknesses between 0,9 mm and 2 mm linear interpolation can be used.

For plate thicknesses between 2 mm and 4 mm the value for 2 mm can be used.

Tensile capacity

The characteristic tensile capacity $F_{tens,k}$, of a Paslode Connector Screw is stated in Table B6 in Annex B depending on the screw type.

Yield moment

The characteristic yield moment $M_{y,k}$, of a Paslode Connector Screw is stated in Table B6 in Annex B depending on the screw type.

Torsional Ratio

The torsional ratio $R_{tor,m}/F_{tor,k}$, of a Paslode Connector Screw is stated in Table B6 in Annex B depending on the screw type.

3.10 Aspects related to the performance of the product

3.10.1 Corrosion protection in service class 1, 2 and 3. Annex A provides for the steel qualities and corrosion protection of the nails and screws.

3.10.2 Three-member connections.

Paslode Connector Nails may overlap in the central member of a three-member connection, if (t-t2) is greater than or equal to 2,5 d_{nom} in mm. The situation is illustrated in the figure below.

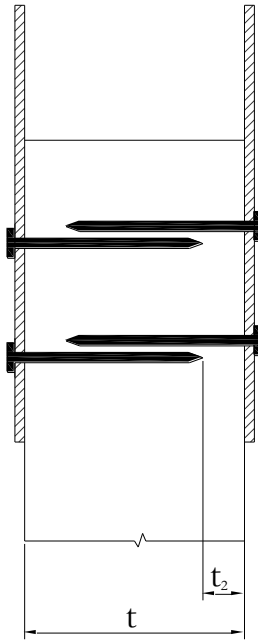

t = the thickness of the timber

t_2 = the penetration depth from the point side.

3.11 General aspects related to the fitness for use of the product

The nails and screws are manufactured in accordance with the provisions of this European Technical Assessment using the manufacturing processes as identified in the inspection of the plant by the notified inspection body and laid down in the technical documentation.

The nails can be driven into the wood with a nailing tool (gas or pneumatic) or manually by hammer.

The screws can be driven into the wood with a screwing machine or manually with a screwdriver. It isn't necessary to predrill holes before installation.

The requirements for the holes in the metal plate is given in Eurocode 5, §8.2.3 (1).

Minimum spacings for Paslode Connector Screws:

As stated in Eurocode 5, clause 8.7.1, paragraph (5) smooth shank screws of a diameter less than 6 mm can be treated as nails. Since the 5 mm connector screws have an inner diameter of 3,2 mm they can be treated as nails with an effective diameter as defined in clause 8.7.1, paragraph (3). That the smooth shank just below the head has a diameter of 5 mm is of no essential importance. The reason why is that according to Eurocode 5, clause 8.7.1, paragraph (3) an effective diameter of screws with a thread over the whole length shall be used instead of the diameter of a smooth shank.

For the connector screws the core diameter is 3,2 mm, so according to clause 8.7.1, paragraph (3) the effective diameter becomes 3,5 mm which is smaller than the 4 mm of a connector nail. Therefore, if you can use 4 mm nail in the connectors the requirements to minimum distances and spacing will be fulfilled also by using 5 mm connector screws.

In Annex B, Table B7 is stated which Paslode Connector Screw to be used as an alternative to a Paslode Connector Nail.

4 Attestation and verification of constancy of performance (AVCP)

4.1 AVCP system

According to the decision 97/638/EC of the European Commission¹, as amended, the system(s) of assessment and verification of constancy of performance (see Annex V to Regulation (EU) No 305/2011) is 2+.

5 Technical details necessary for the implementation of the AVCP system, as foreseen in the applicable EAD

Technical details necessary for the implementation of the AVCP system are laid down in the control plan deposited at ETA-Danmark

Issued in Copenhagen on 2015-04-18 by

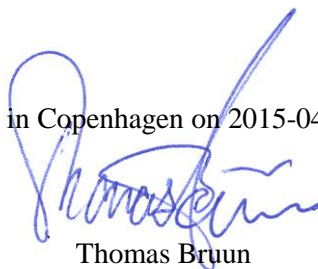



Thomas Bruun
Managing Director, ETA-Danmark

Annex A
Drawings and dimensions with tolerances

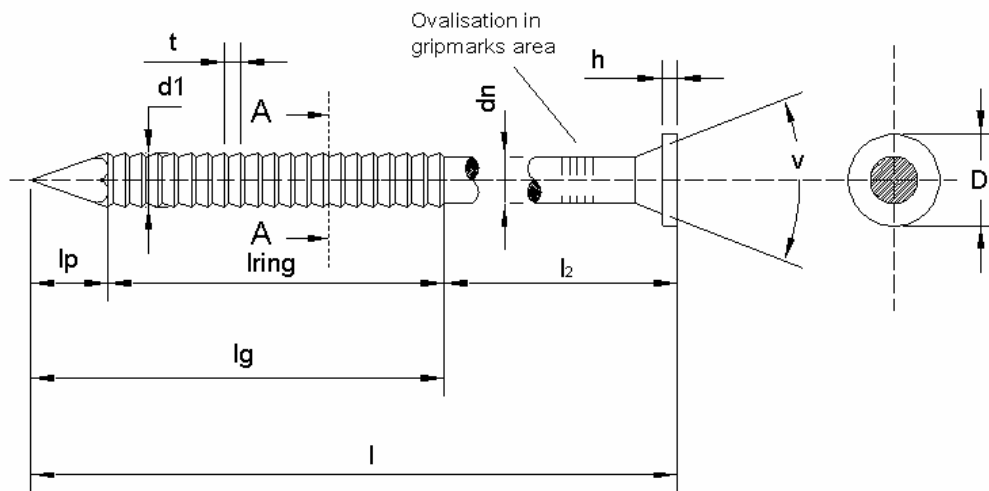

Paslode Connector Nail: Hardened

Diameter = 4,0 mm



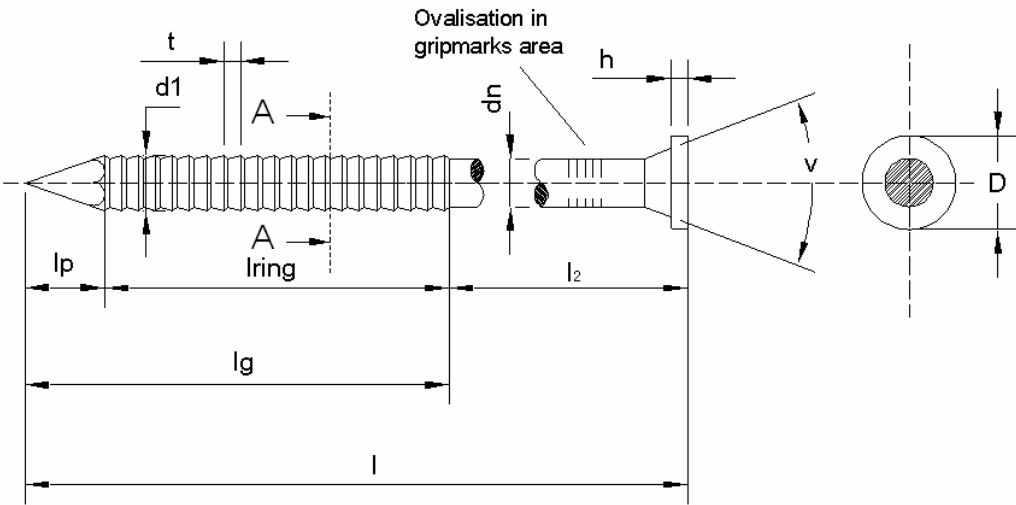

Specification	Shank		Ring		Head	
Dimension (mm)	d_n	l_p	D_1	t	D	h
Version			20 Rings/inch			
Max.	4,1		4,6			
Nom.	4,0	8	4,4	1,27	8	1
Min.	3,9		4,3			
Wire d = 4,00 mm	Range of nail length l (mm)		l_2 (mm)		Min. l_{ring} (mm)	Min. l_q (mm)
	37 ± 1		10		19	27
	42 ± 1		10		24	32
	53 ± 1		10		35	43
	63 ± 1		10		45	53
Quality: wire rod according EN 10016 (DIN 17140), min. tensile strength 600 N/mm ²	Corrosion protection: 1. Electroplated > 12 μ m, Cr (III), hardened		 Drawing: ITW Construction Products Europe Woodfasteners R & D Center Date: 092311		Revision: FSO Date: 091123; 1. JBY 28.01.2010	
Manufacturer: 1. ITW Construction Products ApS, DK - 5500 Middelfart					Checked by: AB	
	Page no. from pages 1 1		Drawing no: 51.400-355/5 51.400-360/6			

Paslode Connector Nail: GALV-PLUS®, HDG, A2 (AISI 304), A4 (AISI 316)

		Diameter = 4,0 mm				
						
Specification	Shank		Ring		Head	
Dimension (mm)	dn	lp	D1	t	D	h
Version			20 Rings/inch			
Max.	4,1		4,6			
Nom.	4,0	6	4,4	1,27	8	1
Min.	3,9		4,3			
Wire d =	Range of nail length l (mm)		l ₂ (mm)		Min. l _{ring} (mm)	Min. l _a (mm)
4,00 mm	37 ± 1		12		19	25
	42 ± 1		12		24	30
	53 ± 1		12		35	41
	63 ± 1		12		45	51
Quality: wire rod according EN 10016 (DIN 17140), min. tensile strength 600 N/mm ²					Revision: FSO Date: 091123; 1. JBY 28.01.2010	
Corrosion protection: 1. HDG 2. GALV-PLUS 3. A4 4. A2					Drawing: ITW Construction Products Europe Woodfasteners R & D Center	
					Date: 092311	
Manufacturer: 1. ITW Construction Products ApS, DK - 5500 Middelfart			Page no. from pages 1 1		Drawing no: 51.400-355/5 51.400-360/6	

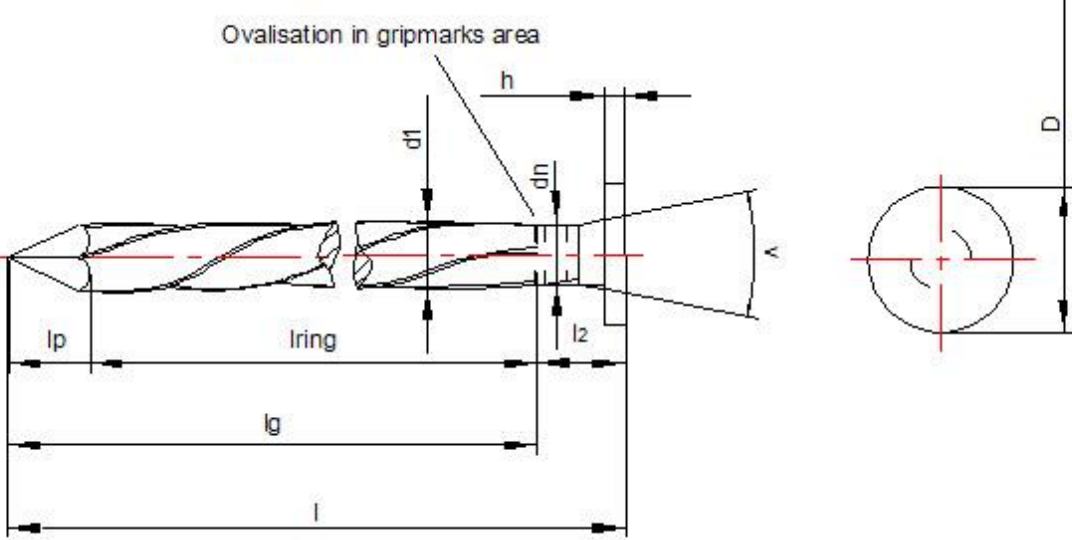
Paslode Connector Nail: UK Twist

		Diameter = 3,4 mm			
					
Specification	Shank		Ring		Head
Dimension (mm)	dn	lp	d1	t	D h
Version					
Max.	3,5		3,9	-	
Nom.	3,4	5	3,7	-	8 1
Min.	3,3		3,6	-	
Wire d =	Range of nail length (mm)		L2 (mm)		Min. l_{req} (mm)
3,38 mm	34 ± 1		9		20
					25
Quality: wire rod according EN 10016 (DIN 17140), min. tensile strength 600 N/mm ²					Revision: JBY 28.01.2010, 20.01.2011
Corrosion protection: 1. Electroplated > 12 µm, Cr (III), hardened 2. Electroplated > 12 µm, Cr (III)			Drawing: ITW Construction Products Europe Woodfasteners R & D Center, J. Bybjerg		Checked by: AB
			Date: 12.01.2010/JBY		
Manufacturer: 1. ITW Construction Products ApS, DK - 5500 Middelfart			Page no. from pages 1 1		Drawing no: VHT UK twist 51.338-661/3

Paslode Connector Nail: UK Ring

	Diameter = 3.4 mm	
---	--------------------------	--

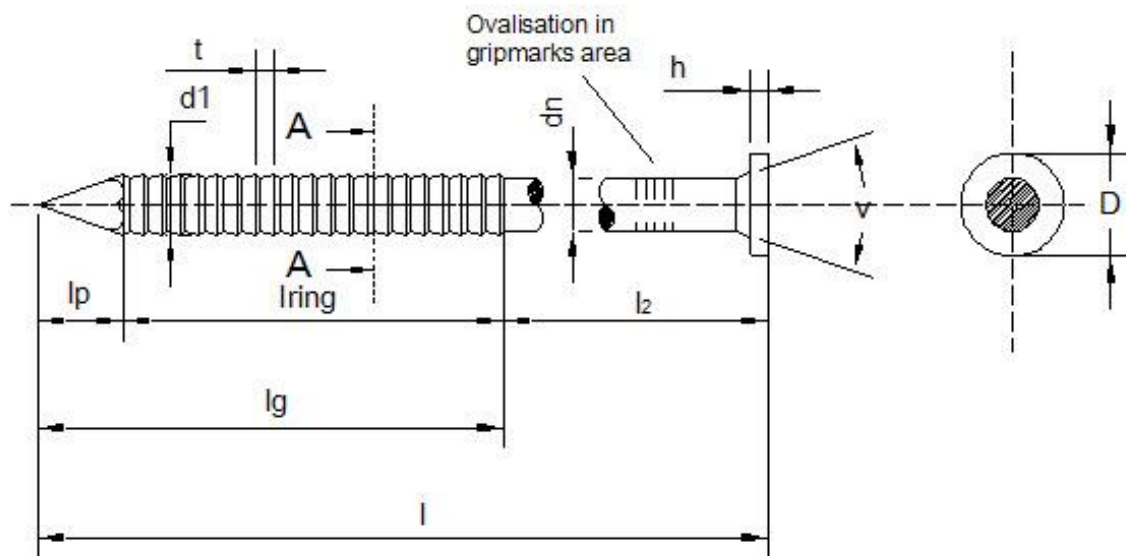

Specification	Shank		Ring		Head	
Dimension (mm)	dn	lp	d1	t	D	h
Version			24 rings/inch			
Max.	3,5		3,9	-		
Nom.	3,4	5	3,7	1,06	8	1
Min.	3,3		3,6	-		

3,38 mm	Wire d =	Range of nail length l (mm)	l ₂ (mm)	Min. l _{ring} (mm)	Min. l _g (mm)
		34 ± 1	9	20	25

Quality: wire rod according EN 10016 (DIN 17140), min. tensile strength 600 N/mm ² Corrosion protection: 1. Electroplated > 12 µm, Cr (III), hardened 2. Electroplated > 12 µm, Cr (III) Manufacturer: 1. ITW Construction Products ApS, DK - 5500 Middelfart		Revision: JBY 28.01.2010, 20.01.2011 Checked by: AB Date: 13.01.2010/JBY Page no. from pages 1 1 Drawing no: VHT UK ring 51.338-261/1
---	---	---

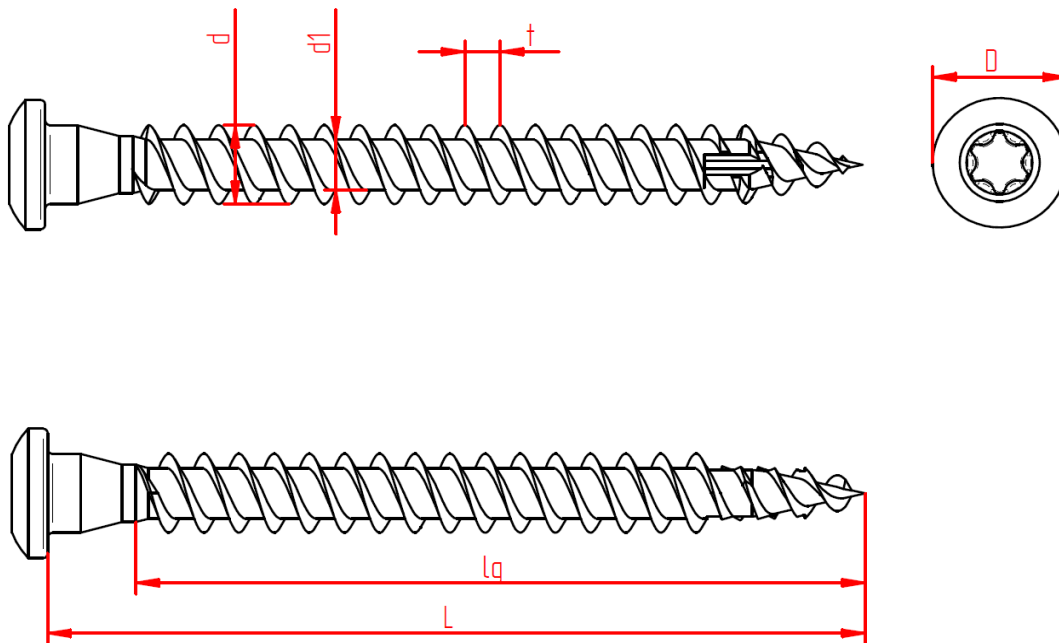

In mm	D	d	d1	t
Norm	8,0	5,0	3,2	2,3
Min.		4,6	3,0	2,0
Max		5,1	3,4	2,6
Nominell l	25	35	40	50
l Max	26,0	36,0	41,0	51,0
l Min.	23,0	33,0	38,0	48,0
lg Min.	18	28	33	43

Material Wire : A2, A4 , Hardenability iron
 Surface : Electroplated

			 CONSTRUCTION PRODUCTS ITW Screws	DRAW.	mf
H				DATE	230610
G			SIGN.		
F			DATE		
E			DRAW. NO.:		
D			Paslode Connector screw 5,0x25-35-40-50 for Building connector		
C					
B			replaces of:		
A	Produkt navn ændret	mf 250111	Edition:	2	
corrections		Sign. Date			

Annex B Characteristic capacities

Table B1

Characteristic capacities for a characteristic density of the wood members as indicated in the Table B1. The nail shall be driven completely into the wood or wood based material, which shall have a thickness of at least the length of the nail. The values given in Table B1 presuppose that the profiled part of the nail is completely embedded in the wood or wood based material.

Nail mm × mm	$f_{ax,k}$ N/mm ²	C18 ($\rho_k = 320 \text{ kg/m}^3$)			C24 ($\rho_k = 350 \text{ kg/m}^3$)			C30 ($\rho_k = 380 \text{ kg/m}^3$)		
		$F_{ax,Rk}$ N	$F_{v,Rk}$		$F_{ax,Rk}$ N	$F_{v,Rk}$		$F_{ax,Rk}$ N	$F_{v,Rk}$	
			Thin N	Thick N		Thin N	Thick N		Thin N	Thick N
4,0 × 35	7,5	524	1342	1458	573	1467	1595	622	1593	1732
4,0 × 40	10,7	939	1716	1865	1027	1877	2040	1115	2038	2215
4,0 × 50	10,7	1370	2051	2230	1498	2244	2439	1626	2436	2648
4,0 × 60	10,7	1761	2373	2580	1926	2596	2822	2091	2818	3064

$f_{ax,k}$ Characteristic withdrawal parameter

$F_{ax,Rk}$ Characteristic withdrawal (axial) capacity per nail

For $F_{ax,Rk}$

- nails type GalvPlus®, HDG, A2 (AISI 304), A4 (AISI 316), 4,0 × 35, can be multiplied with 1,33
- values for other densities (ρ_k) can be calculated by multiplying the values for C24 with $\rho_k/350$

$F_{v,Rk}$ Characteristic load-carrying capacity per shear plane per nail

Thin Refers to plates with a thickness = 0,9 mm

Thick Refers to plates with a thickness = 2 mm

For $F_{v,Rk}$

- nails type HDG have to be multiplied with 0,93
- nails type A2 (AISI 304) have to be multiplied with 0,96
- nails type GalvPlus®, HDG, A2 (AISI 304), A4 (AISI 316), 4,0 × 35, can be multiplied with 1,15
- nails type A4 (AISI 316) can be multiplied with 1,06
- the values can be multiplied with 1,12 for loads perpendicular to grain
- plates with 0,9 mm < thickness < 2 mm, capacities can be interpolated
- values are only valid for plates with a thickness ≤ 4 mm
- values for other densities (ρ_k) can be calculated by multiplying the values for C24 with $\rho_k/350$

Table B2

Characteristic tensile capacity and yield moment for the different nail types.

Nail type	$F_{tens,k}$ N	$M_{y,Rk}$ Nmm
Hardened	16170	15864
GalvPlus®	9200	9875
HDG	7480	7445
A2 (AISI 304)	-	8370
A4 (AISI 316)	9630	12310

$F_{tens,k}$ Characteristic tensile capacity

$M_{y,Rk}$ Characteristic yield moment

Characteristic capacities for UK nails with a diameter of 3,4 mm

Table B3

Characteristic capacities for a characteristic density of the wood members as indicated in the Table B3. The nail shall be driven completely into the wood or wood based material, which shall have a thickness of at least the length of the nail. The values given in Table B3 presuppose that the profiled part of the nail is completely embedded in the wood or wood based material.

Nail mm × mm	$f_{ax,k}$ N/mm ²	C18 ($\rho_k = 320 \text{ kg/m}^3$)			C24 ($\rho_k = 350 \text{ kg/m}^3$)			C30 ($\rho_k = 380 \text{ kg/m}^3$)		
		$F_{ax,Rk}$ N	$F_{v,Rk}$		$F_{ax,Rk}$ N	$F_{v,Rk}$		$F_{ax,Rk}$ N	$F_{v,Rk}$	
			Thin N	Thick N		Thin N	Thick N		Thin N	Thick N
UK Twist	6,3	392	903	951	428	988	1040	465	1073	1129
UK Ring	7,1	443	1129	1189	485	1235	1300	526	1341	1411

$f_{ax,k}$ Characteristic withdrawal parameter

$F_{ax,Rk}$ Characteristic withdrawal (axial) capacity per nail

For $F_{ax,Rk}$

- not hardened UK Ring can be multiplied with 1,33.

- values for other densities (ρ_k) can be calculated by multiplying the values for C24 with $\rho_k/350$

$F_{v,Rk}$ Characteristic load-carrying capacity per shear plane per nail

For $F_{v,Rk}$

- not hardened nails have to be multiplied with 0,9.

- the values can be multiplied with 1,30 for loads perpendicular to grain

- plates with 0,9 mm < thickness < 2 mm, capacities can be interpolated

- values are only valid for plates with a thickness ≤ 4 mm

- values for other densities (ρ_k) can be calculated by multiplying the values for C24 with $\rho_k/350$

Table B4

Characteristic tensile capacity and yield moment for the different nail types.

Nail type	$F_{tens,k}$ N	$M_{y,Rk}$ Nmm
Hardened		
UK Twist	9740	8342
UK Ring	9653	7840
Not hardened		
UK Twist	-	4940
UK Ring	-	4190

$F_{tens,k}$ Characteristic tensile capacity

$M_{y,Rk}$ Characteristic yield moment

Characteristic capacities for screws with a diameter of 5 mm**Table B5**

Characteristic capacities for a characteristic density of the wood members as indicated in the Table B5. The screw shall be driven completely into the wood or wood based material, which shall have a thickness of at least the length of the screw. The values given in Table B5 presuppose that the threaded part of the screw is completely embedded in the wood or wood based material.

Screw mm × mm	$f_{ax,k}$ N/mm ²	C18 ($\rho_k = 320 \text{ kg/m}^3$)			C24 ($\rho_k = 350 \text{ kg/m}^3$)			C30 ($\rho_k = 380 \text{ kg/m}^3$)		
		$F_{ax,Rk}$ N	$F_{v,Rk}$		$F_{ax,Rk}$ N	$F_{v,Rk}$		$F_{ax,Rk}$ N	$F_{v,Rk}$	
			Thin N	Thick N		Thin N	Thick N		Thin N	Thick N
5,0 x 25	15,2	903	1214	1349	988	1328	1475	1073	1441	1601
5,0 x 35	15,2	1598	1699	1888	1748	1859	2065	1898	2018	2242
5,0 x 40	15,2	1946	1942	2158	2128	2124	2360	2310	2306	2562
5,0 x 50	15,2	2640	2427	2697	2888	2655	2950	3136	2883	3203

$f_{ax,k}$ Characteristic withdrawal parameter

$F_{ax,Rk}$ Characteristic withdrawal (axial) capacity per screw

For $F_{ax,Rk}$

- values for other densities (ρ_k) can be calculated by multiplying the values for C24 with $\rho_k/350$

$F_{v,Rk}$ Characteristic load-carrying capacity per shear plane per screw

Thin Refers to plates with a thickness = 0,9 mm

Thick Refers to plates with a thickness = 2 mm

For $F_{v,Rk}$

- the values can be multiplied with 1,08 for loads perpendicular to grain

- plates with 0,9 mm < thickness < 2 mm, capacities can be interpolated

- values are only valid for plates with a thickness ≤ 4 mm

- values for other densities (ρ_k) can be calculated by multiplying the values for C24 with $\rho_k/350$

Table B6

Characteristic tensile capacity, yield moment and torsional ratio for the 2 screw types.

Screw type	$F_{tens,k}$ N	$M_{y,Rk}$ Nmm	$R_{tor,m}/F_{tor,k}$ -
Paslode connector screw	9,73	6483	5,7
Paslode connector screw, stainless	7,52	4573	3,0

$F_{tens,k}$ Characteristic tensile capacity

$M_{y,Rk}$ Characteristic yield moment

$R_{tor,m}/F_{tor,k}$ Torsional ratio

Screws as an alternative fastener in a nails based documentation for connector plates

Table B7

Declared values for connector plates are often based on nails as fasteners. Regardless if the declaration is based on calculations or full scale testing this table states the minimum screw length to be used as an alternative.

The Table is valid for all types of Paslode Connector Nails and Screws covered by this ETA. For A4 nails the values in Table B1 is maximum values and $F_{v,Rk}$ can't be increased as written in the notes.

The Table can only be used to find a screw as an alternative to a nail. It can't be used to find a nail as an alternative to a screw.

Paslode Connector Nail	can be replaced by Paslode Connector Screw
Ring shank	
3,4 × 35	5,0 × 25
4,0 × 35	5,0 × 35
4,0 × 40	5,0 × 35
4,0 × 50	5,0 × 50
4,0 × 60	5,0 × 50
Twisted	
3,4 × 35	5,0 × 25